



## Immigrants' Rights and Resource Guide

*This document is intended for educational, civic, and advocacy purposes. This is not provided by our legal team, nor does anything in this document constitute legal advice. Please contact [media@acluct.org](mailto:media@acluct.org) with any questions.*

### What does immigration law in Connecticut look like?

First and foremost, **immigration law is complicated**. Our role is to provide you with the information that we have to ensure you know your rights as someone with an immigration status in Connecticut.

Nationally, the federal government regulates and enforces immigration law. States can have laws that govern how immigrants navigate things in their state but generally cannot regulate immigration through state law.

For instance, in Connecticut, we have the **Trust Act, a statute that regulates how state and local law enforcement interact with federal immigration authorities**. It limits the information that state and local law enforcement can share with federal immigration authorities and prohibits them from detaining someone for Immigration and Customs Enforcement (ICE), except under limited circumstances.

### What is the Trust Act?

In broad strokes, the Trust Act **prevents local and state law enforcement from cooperating with federal immigration authorities, except under limited circumstances**.

Over years it has been updated several times. In its current form, the Trust Act limits local and state law enforcement's authority to:

- Arrest or detain an individual pursuant to a civil immigration detainer;
- Arrest or detain an individual based on an administrative warrant;
- Expend or use time, money, facilities, property, equipment, personnel or other resources to communicate with a federal immigration authority;
- Give federal immigration authorities access to interview an individual who is in the custody of a law enforcement agency; and
- Perform any function of a federal immigration authority.

The Trust Act also **helps ensure access to information about any law enforcement cooperation with ICE**. The law deems all records relating to ICE access as public records—which we all have the right to access—under the state's Freedom of Information Act and imposes reporting requirements on municipalities that cooperate with ICE.

Finally, yet critically, the Trust Act now **allows individuals to sue for violations of the Act**.

Despite these protections, **the Trust Act is not ironclad**. It is designed to prevent state and local cooperation with the federal government, but it does not directly protect individuals from actions taken by federal immigration officials. Among other things, the Trust Act also does not restrict local officials' authority to cooperate with federal authorities seeking to detain individuals who were convicted of certain serious crimes; individuals identified on terrorism screening databases, and individuals who are the subject of certain court orders.

For these reasons and more, **advocates across the state are continuing to push for more meaningful protections**.

# ACLU

## Connecticut

### What are my rights as an immigrant in Connecticut?

**Regardless of immigration status, people in the United States have fundamental constitutional rights.** These rights include the right to remain silent, the right to due process, the right to speak with an attorney, protection from unlawful search and detention, and others.

We know that this doesn't cover everything, but knowing these rights can help you protect yourself, your family, and your neighbors when interacting with law enforcement or immigration officials. Here are some scenarios and general guidance where knowing your rights is critical:

- **What happens if I get stopped by non-immigration law enforcement (IE: local police)?**
  - In Connecticut, if state or municipal officers ask for your name or identification while you are in public, you do not need to tell them, but the refusal to do so can amount to criminal interference. To be safe, you may wish to identify yourself.
  - If you are driving a vehicle, you are required to provide your ID to police upon request.
  - If state or local officers ask questions about your immigration status, you do not need to answer their questions. You always have the right to remain silent and do not have to discuss your immigration or citizenship status.
- **What happens if I get stopped by immigration agents in Connecticut?**
  - If you are an American citizen, and if federal immigration officials ask for your name or identification, you have no obligation to comply.
  - If you are not an American citizen and if you have papers, carry them with you at all times, if you are over 18. If an immigration agent requests your immigration papers, you must show them if you have them with you. If you don't have them, tell the officer that you want to remain silent, or that you want to consult a lawyer before answering any questions.
  - No matter your immigration status, you always have the right to remain silent and do not have to discuss your immigration or citizenship status with police, immigration agents, or other officials. Remember that anything you tell an officer can later be used against you in immigration court.
  - No matter the scenario, it's best not to lie or carry false documents with you.
- **What can I do if ICE comes to my home?**
  - You do not have to open the door.
  - You can ask the officials if they have a warrant. You can ask the officials to pass the warrant under the door.
  - You should confirm that the warrant has been signed by a judge or magistrate and that it has your correct name and address on it. Only a warrant signed by a judge or magistrate with your correct name allows immigration officials to enter your home to make an arrest. And only a warrant signed by a judge or magistrate with the correct address allows an official to enter your home to search it.
  - Remember that an administrative warrant of arrest (Form I-200) or deportation (Form I-205) does not allow officers to enter a home without consent.
  - You have the right to remain silent, even if the officer has a warrant.
  - If they enter your home anyway, you have the right to ask for the names and badge numbers of the officer. You can also say that you did not consent to their entry.
  - If immigration officials take items from your home, keep a record of what they took and ask them for a record of the items taken.

*[CONTINUED ON THE NEXT PAGE]*

# ACLU

## Connecticut

### What are my rights as an immigrant in Connecticut? (cont.)

- **What can I do if ICE comes to my workplace?**
  - First, it is important to know that ICE does not need a warrant or permission to enter the public spaces of a business such as the dining room in a restaurant. But they do need a warrant or permission to enter areas that are not open to the public, such as the kitchen in a restaurant.
  - If ICE seeks to enter areas that are not open to the public, you can ask the officials if they have a judicial warrant.
  - As always, you always have the right to remain silent and do not have to discuss your immigration or citizenship status. Anything you tell an officer can later be used against you in immigration court.
- **What can you do if you are detained by ICE?**
  - After you are detained, you still have the right to remain silent. If you wish to exercise that right, say so out loud.
  - You should ask to speak with an attorney, even if you do not yet have one. If you already have a lawyer, you have the right to speak with them.
  - You can ask for a copy of the detainee handbook.
  - You can also ask to make a phone call. It's a good idea to memorize the phone number of your lawyer or a family member or a trusted friend, ideally someone who is in the United States legally, so that you can call them in case of detention.
  - You do not have to give information or answer any questions about your immigration status. You do not have to sign any documents.

We know that this doesn't cover everything, but we want to make sure you know your rights in common scenarios that we've seen and heard of across the state. Find more scenarios like these at <https://www.aclu.org/know-your-rights/immigrants-rights>.

# Know Your Rights Resources

- **ACLU National's Know Your Rights: Immigrants' Rights**
  - This includes info for being stopped by ICE or police, police asking about immigration status, police or ICE at home, needing a lawyer, being detained by Border Patrol, being stopped while in transit, being detained with an active immigration case, needing a deportation order challenge while arrested, and more.
  - ACLU National also has a clear and concise video explainer for what you should do if you're **stopped by ICE or police** as someone with an immigration status.
- **CT Students for a Dream Community Resources**
  - This includes items such as an **ICE Activity Report**, a **Detention Referral Form**, **Know-Before-You-Go's**, and much more.
- **CT Legal Services' One-Pager for Legal Assistance for Undocumented Minors in CT**
- **Hartford Deportation Defense Fund's Resource Guide Directory**
  - This is an expansive directory of resources including houselessness support, youth services, mental health resources, SA/DV resources, addiction recovery resources, legal aid, etc.
- **National Immigration Law Center's Know Your Rights**
  - This includes multilingual guides for employers if ICE comes to your workplace, students and teachers if ICE comes to your school, expedited removals, warrants and subpoenas, detainees, finding someone after arrest, arrests at airports, and much more.
  - NILC also has a **toolkit for organizations responding to mass worksite raids**
- **Immigration Legal Resource Center Community Resources**
  - This includes printable **Red Cards in over 50 languages**, and a **family preparedness plan and toolkit**.
- **Immigration Advocates Network National Legal Services Directory**
- **Mobilization for Justice Know Your Rights Guides**
  - For Interacting with **ICE in Public Spaces**
  - For Interacting with **ICE at Home**
  - For Interacting with **ICE in Courts**
- **Know Your Rights: Immigration in CT**
  - This was produced by CT Legal Services, Greater Hartford Legal Aid, NHLAA, and Statewide Legal Services of CT

# Trusted Legal Aid Organizations in Connecticut

2-1-1 of Connecticut has more resources for immigrants [here](#).

This page will be updated as more resources become available.

- **Greater Hartford Legal Aid**
  - <https://www.ghla.org/>
  - (860) 541-5000
- **Connecticut Legal Services**
  - <https://ctlegal.org/>
  - (860) 225-8678
- **New Haven Legal Assistance**
  - <https://nhlegal.org/>
  - (203) 946-4811
- **Connecticut Institute for Refugees and Immigrants**
  - <https://cirict.org/>
    - Bridgeport: (203) 336-0414
    - Stamford: (203) 965-7190
    - Hartford: (860) 692-3085
- **Apostle Immigrant Services**
  - <https://www.apostleimmigrantservices.org/>
  - (203) 752-9068
- **IRIS - Integrated Refugee and Immigrant Services**
  - <https://irisct.org/>
  - (203) 562-2095
- **Building One Community**
  - <https://building1community.org/>
  - (203) 674-8585
- **Yale Law School's Legal Assistance: Immigrant Rights Clinic (IRC)**
  - <https://law.yale.edu/studying-law-yale/clinical-and-experiential-learning/our-clinics/legal-assistance-immigrant-rights-clinic>
- **University of Connecticut School of Law, Asylum and Human Rights Clinic**
  - <https://www.law.uconn.edu/academics/clinics-experiential-learning/asylum-human-rights-clinic>
  - (860) 570-5165
- **Immigration Advocates Network**
  - <http://www.immigrationadvocates.org/nonprofit/legaldirectory>
- **American Immigration Lawyers Association**
  - <https://www.aila.org/>
  - 1 (800) 954-0254

## Red Card Cut-Outs (ENGLISH)

To print at home, use heavy weight paper, or card stock. Cut out the cards along the dotted lines. If you're unable to print on both sides, you can simply fold on the center line to make a 2-sided card.

If you use a professional printer, we suggest you print 2-sided cards with white text on red card stock with rounded corners.

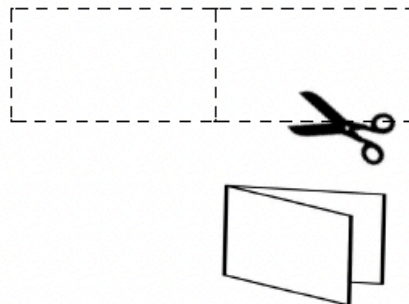

You have constitutional rights:

- **DO NOT OPEN THE DOOR** if an immigration agent is knocking on the door.
- **DO NOT ANSWER ANY QUESTIONS** from an immigration agent if they try to talk to you. You have the right to remain silent.
- **DO NOT SIGN ANYTHING** without first speaking to a lawyer. You have the right to speak with a lawyer.
- If you are outside of your home, ask the agent if you are free to leave and if they say yes, leave calmly.
- **GIVE THIS CARD TO THE AGENT.** If you are inside of your home, show the card through the window or slide it under the door.

I do not wish to speak with you, answer your questions, or sign or hand you any documents based on my 5th Amendment rights under the United States Constitution.

I do not give you permission to enter my home based on my 4th Amendment rights under the United States Constitution unless you have a warrant to enter, signed by a judge or magistrate with my name on it that you slide under the door.

I do not give you permission to search any of my belongings based on my 4th Amendment rights.

I choose to exercise my constitutional rights.

*These cards are available to citizens and noncitizens alike.*

You have constitutional rights:

- **DO NOT OPEN THE DOOR** if an immigration agent is knocking on the door.
- **DO NOT ANSWER ANY QUESTIONS** from an immigration agent if they try to talk to you. You have the right to remain silent.
- **DO NOT SIGN ANYTHING** without first speaking to a lawyer. You have the right to speak with a lawyer.
- If you are outside of your home, ask the agent if you are free to leave and if they say yes, leave calmly.
- **GIVE THIS CARD TO THE AGENT.** If you are inside of your home, show the card through the window or slide it under the door.

I do not wish to speak with you, answer your questions, or sign or hand you any documents based on my 5th Amendment rights under the United States Constitution.

I do not give you permission to enter my home based on my 4th Amendment rights under the United States Constitution unless you have a warrant to enter, signed by a judge or magistrate with my name on it that you slide under the door.

I do not give you permission to search any of my belongings based on my 4th Amendment rights.

I choose to exercise my constitutional rights.

*These cards are available to citizens and noncitizens alike.*

You have constitutional rights:

- **DO NOT OPEN THE DOOR** if an immigration agent is knocking on the door.
- **DO NOT ANSWER ANY QUESTIONS** from an immigration agent if they try to talk to you. You have the right to remain silent.
- **DO NOT SIGN ANYTHING** without first speaking to a lawyer. You have the right to speak with a lawyer.
- If you are outside of your home, ask the agent if you are free to leave and if they say yes, leave calmly.
- **GIVE THIS CARD TO THE AGENT.** If you are inside of your home, show the card through the window or slide it under the door.

I do not wish to speak with you, answer your questions, or sign or hand you any documents based on my 5th Amendment rights under the United States Constitution.

I do not give you permission to enter my home based on my 4th Amendment rights under the United States Constitution unless you have a warrant to enter, signed by a judge or magistrate with my name on it that you slide under the door.

I do not give you permission to search any of my belongings based on my 4th Amendment rights.

I choose to exercise my constitutional rights.

*These cards are available to citizens and noncitizens alike.*

You have constitutional rights:

- **DO NOT OPEN THE DOOR** if an immigration agent is knocking on the door.
- **DO NOT ANSWER ANY QUESTIONS** from an immigration agent if they try to talk to you. You have the right to remain silent.
- **DO NOT SIGN ANYTHING** without first speaking to a lawyer. You have the right to speak with a lawyer.
- If you are outside of your home, ask the agent if you are free to leave and if they say yes, leave calmly.
- **GIVE THIS CARD TO THE AGENT.** If you are inside of your home, show the card through the window or slide it under the door.

I do not wish to speak with you, answer your questions, or sign or hand you any documents based on my 5th Amendment rights under the United States Constitution.

I do not give you permission to enter my home based on my 4th Amendment rights under the United States Constitution unless you have a warrant to enter, signed by a judge or magistrate with my name on it that you slide under the door.

I do not give you permission to search any of my belongings based on my 4th Amendment rights.

I choose to exercise my constitutional rights.

*These cards are available to citizens and noncitizens alike.*

## Red Card Cut-Outs (SPANISH)

Para imprimir en casa, utilice papel grueso o cartulina. Recorta las tarjetas por las líneas de puntos. Si no puede imprimir en ambas caras, simplemente puede doblar por la línea central para hacer una tarjeta de dos caras.

Si utiliza una impresora profesional, le sugerimos que imprima tarjetas de 2 caras con texto blanco en cartulina roja con esquinas redondeadas.

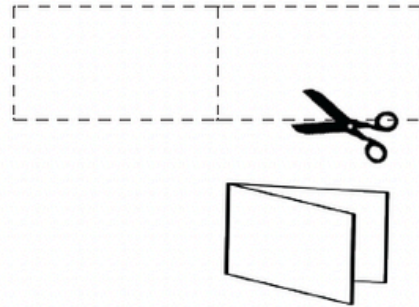

### Usted tiene derechos constitucionales:

- **NO ABRA LA PUERTA** si un agente de inmigración está tocando la puerta.
- **NO CONTESTE NINGUNA PREGUNTA** de un agente de inmigración si el trata de hablar con usted. Usted tiene el derecho de mantenerse callado.
- **NO FIRME NADA** sin antes hablar con un abogado. Usted tiene el derecho de hablar con un abogado.
- Si usted está afuera de su casa, pregunte al agente si es libre para irse y si dice que sí, váyase con tranquilidad.
- **ENTREGUE ESTA TARJETA AL AGENTE.** Si usted está dentro de su casa, muestre la tarjeta por la ventana o pásela debajo de la puerta.

### Usted tiene derechos constitucionales:

- **NO ABRA LA PUERTA** si un agente de inmigración está tocando la puerta.
- **NO CONTESTE NINGUNA PREGUNTA** de un agente de inmigración si el trata de hablar con usted. Usted tiene el derecho de mantenerse callado.
- **NO FIRME NADA** sin antes hablar con un abogado. Usted tiene el derecho de hablar con un abogado.
- Si usted está afuera de su casa, pregunte al agente si es libre para irse y si dice que sí, váyase con tranquilidad.
- **ENTREGUE ESTA TARJETA AL AGENTE.** Si usted está dentro de su casa, muestre la tarjeta por la ventana o pásela debajo de la puerta.

### Usted tiene derechos constitucionales:

- **NO ABRA LA PUERTA** si un agente de inmigración está tocando la puerta.
- **NO CONTESTE NINGUNA PREGUNTA** de un agente de inmigración si el trata de hablar con usted. Usted tiene el derecho de mantenerse callado.
- **NO FIRME NADA** sin antes hablar con un abogado. Usted tiene el derecho de hablar con un abogado.
- Si usted está afuera de su casa, pregunte al agente si es libre para irse y si dice que sí, váyase con tranquilidad.
- **ENTREGUE ESTA TARJETA AL AGENTE.** Si usted está dentro de su casa, muestre la tarjeta por la ventana o pásela debajo de la puerta.

### Usted tiene derechos constitucionales:

- **NO ABRA LA PUERTA** si un agente de inmigración está tocando la puerta.
- **NO CONTESTE NINGUNA PREGUNTA** de un agente de inmigración si el trata de hablar con usted. Usted tiene el derecho de mantenerse callado.
- **NO FIRME NADA** sin antes hablar con un abogado. Usted tiene el derecho de hablar con un abogado.
- Si usted está afuera de su casa, pregunte al agente si es libre para irse y si dice que sí, váyase con tranquilidad.
- **ENTREGUE ESTA TARJETA AL AGENTE.** Si usted está dentro de su casa, muestre la tarjeta por la ventana o pásela debajo de la puerta.

I do not wish to speak with you, answer your questions, or sign or hand you any documents based on my 5th Amendment rights under the United States Constitution.

I do not give you permission to enter my home based on my 4th Amendment rights under the United States Constitution unless you have a warrant to enter, signed by a judge or magistrate with my name on it that you slide under the door.

I do not give you permission to search any of my belongings based on my 4th Amendment rights.

I choose to exercise my constitutional rights.

*These cards are available to citizens and noncitizens alike.*

I do not wish to speak with you, answer your questions, or sign or hand you any documents based on my 5th Amendment rights under the United States Constitution.

I do not give you permission to enter my home based on my 4th Amendment rights under the United States Constitution unless you have a warrant to enter, signed by a judge or magistrate with my name on it that you slide under the door.

I do not give you permission to search any of my belongings based on my 4th Amendment rights.

I choose to exercise my constitutional rights.

*These cards are available to citizens and noncitizens alike.*

I do not wish to speak with you, answer your questions, or sign or hand you any documents based on my 5th Amendment rights under the United States Constitution.

I do not give you permission to enter my home based on my 4th Amendment rights under the United States Constitution unless you have a warrant to enter, signed by a judge or magistrate with my name on it that you slide under the door.

I do not give you permission to search any of my belongings based on my 4th Amendment rights.

I choose to exercise my constitutional rights.

*These cards are available to citizens and noncitizens alike.*

I do not wish to speak with you, answer your questions, or sign or hand you any documents based on my 5th Amendment rights under the United States Constitution.

I do not give you permission to enter my home based on my 4th Amendment rights under the United States Constitution unless you have a warrant to enter, signed by a judge or magistrate with my name on it that you slide under the door.

I do not give you permission to search any of my belongings based on my 4th Amendment rights.

I choose to exercise my constitutional rights.

*These cards are available to citizens and noncitizens alike.*